

SERIE PA



PA 1250

37.8400.97.3 - VD
37.8410.97.3 - VM

Pompa a 3 membrane-pistone semidrauliche.
Three piston semi-hydraulic diaphragm pump.
Pompe à 3 piston-membranes semi-hydrauliques.
Bomba de 3 membranas- pistón semi-hidráulicas.

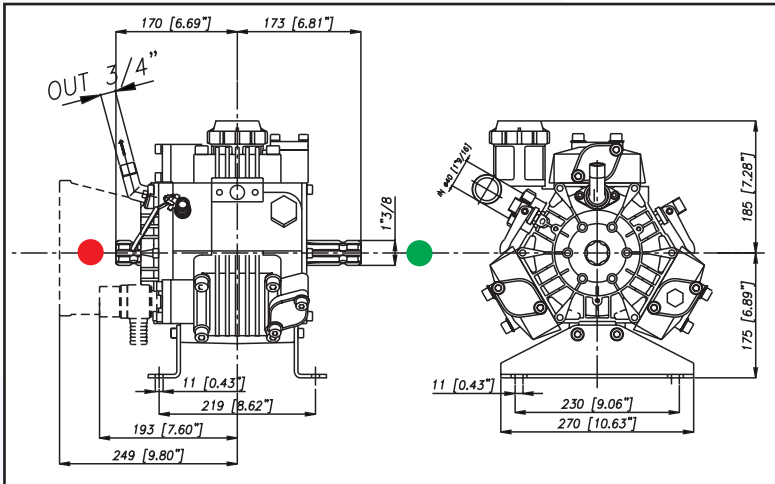

Caratteristiche tecniche
Specifications
Caractéristiques techniques
Características técnicas

Mod. PA 1250

TABELLA RENDIMENTI - PERFORMANCE CHART
TABLEAU DES PERFORMANCES - TABLA DE RENDIMIENTOS

g/min; R.P.M.; t/min; rev./min.	g/min	R.P.M.	550	550	
Potenza - Power - Puissance - Potencia	KW	HP	11,8	15,7	
Peso - Weight - Poids - Peso	Kg	lb	36	79	
Dislivello aspirazione <i>Negative pressure</i> <i>Pression négative</i> <i>Presión negativa</i>	MAX	mt	ft	1,5	4,9
	<i>Servizio discontinuo</i> <i>Discontinuos service</i> <i>Emploi discontinu</i> <i>Servicio discontinuo</i>	mt	ft	3	9,8
Aspirazione - Ø Intake - Aspiration - Aspiración	mm	in	40	1"9/16	
Mandata - Ø High pressure - Refoulement - Presión	mm	in	G.3/4	G.3/4	
Temperatura - MAX Temperature - Température - Temperatura	°C	°F	60	140	
Tipo olio - Oil type - Type Huile - Tipo aceite	SAE	W	SAE 30	30 W	
Capacità olio - Oil capacity - Capacité huile - Capacidad aceite	lt	U.S.G.	1,25	0,33	

PA 1250	g./min. - R.P.M. - t/min. - rev./min.								
	400		450		500		550		
BAR	P.S.I.	L/min	KW	L/min	KW	L/min	KW	L/min	KW
		USGPM	HP	USGPM	HP	USGPM	HP	USGPM	HP
2	29	90,9	0,4	102,3	0,4	113,6	0,4	125,0	0,5
		24,0	0,5	27,0	0,5	30,0	0,6	33,0	0,7
20	290	89,5	3,5	100,6	4,0	111,8	4,4	123,0	4,8
		23,6	4,7	26,6	5,3	29,5	5,9	32,5	6,5
40	580	88,0	6,9	99,0	7,8	110,0	8,6	121,0	9,5
		23,2	9,2	26,2	10,4	29,1	11,5	32,0	12,7
50	725	87,3	8,6	98,2	9,6	109,1	10,7	120,0	11,8
		23,1	11,4	25,9	13,9	28,8	14,3	31,7	15,7



ALBERO POMPA • PUMP SHAFT • ARBRE POMPE • CIGÜEÑAL BOMBA



● ANT. - FRONT
● AVANT - ANTERIOR



● POST. - REAR
● ARRIÈRE - POSTERIOR



● POST. - REAR
● ARRIÈRE - POSTERIOR

