

highest quality state of the art CUSTOMER QUALITY PRECISION

BXG 1"

CARATTERISTICHE - SPECIFICATIONS

IN	DIAMETER	∅	3/8 BSP
	PRESS.	Min.	1 bar 15 PSI
		Max.	6 bar 87 PSI
TEMP.	Max.	60° C. 140° F.	
OUT	DIAMETER	∅	3/8 BSP
SHAFT		∅	HOLLOW 1"
OIL	SAE 75W 90		0.14 litri 0.03 U.S.G.
PESO WEIGHT	Kg lbs		7 / 15.4

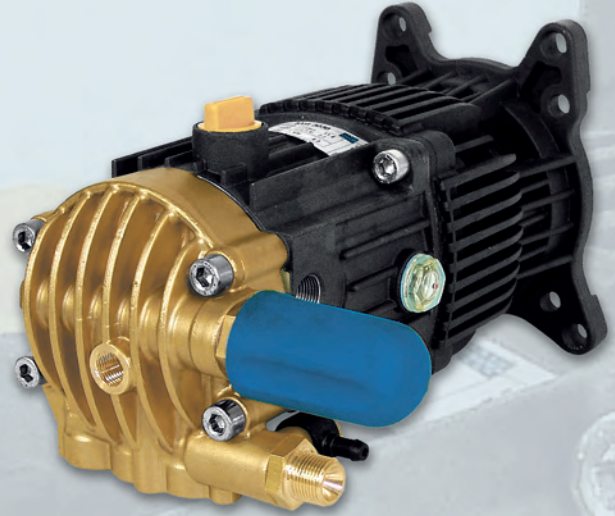

M SAE J609 -1"



Con valvola depressurizzatrice e eiettore fisso incorporati
 With unloader valve and fixed injector built-in
 Avec régulateur de pression et injecteur fixe incorporés
 Con válvula de regulación de presión y eyector fijo incorporados

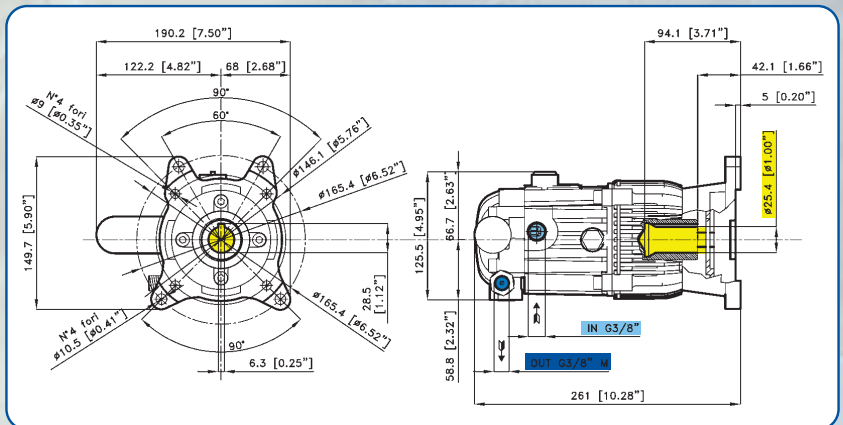

CARATTERISTICHE - FEATURES

BXG 1" 3450 rpm

PERFORMANCE CHART

CODICE CODE	MODELLO MODEL	UGELLO NOZZLE	PRESS MAX MAX PRESSURE		PORTATA FLOW		POTENZA POWER			PIST. PLUNG. Dia. mm	CORSA STROKE mm
			Bar	PSI	L/min	GPM	KW	HP	HP engine		
01.6039.97.3	BXG 2630	035	180	2600	11.4	3.0	3.9	5.3	7 HP	15	6.8
01.6020.97.3	BXG 3030	03	210	3000	11.4	3.0	4.5	6.1	8 HP		
01.6040.97.3	BXG 2635	04	180	2600	13.2	3.5	4.5	6.1	8 HP	15	8.2
01.6021.97.3	BXG 3035	035	210	3000	13.2	3.5	5.2	6.9	9 HP		

Tutti i modelli standard sono forniti con eiettore fisso ed ugello adeguato alla portata, mandata 3/8 BSP M
 All models are standard supplied with fixed injector and equivalent nozzle, outlet 3/8 BSP M
 Tous les modèles sont équipés d'injecteur fixe et buse conforme au débit, refoulement 3/8 BSP M.
 Todos los modelos estándar se proveen dotados con eyector regulable y boquilla adecuada al caudal, envío 3/8 BSP M.

Mandata M 22x1.5
 Mandata 3/8 NPT
 Eiettore fisso ugello 1.8
 Eiettore fisso ugello 2.1
 Eiettore fisso ugello 2.3
 Senza eiettore

Outlet M 22x1.5
 Outlet 3/8 NPT
 Fixed injector nozzle 1.8
 Fixed injector nozzle 2.1
 Fixed injector nozzle 2.3
 Without injector

OPTIONAL

Refoulement M 22x1.5
 Refoulement 3/8 NPT
 Injecteur fixe buse 1.8
 Injecteur fixe buse 2.1
 Injecteur fixe buse 2.3
 Sans Injecteur

Envío M 22x1.5
 Envío 3/8 NPT
 Eyector fijo boquilla 1.8
 Eyector fijo boquilla 2.1
 Eyector fijo boquilla 2.3
 Sin eyector