

highest quality state of the art CUSTOMER QUALITY PRECISION

BXH-F

CARATTERISTICHE - SPECIFICATIONS

| | | | |
|-------------|----------|----------------|------------------------|
| IN | DIAMETER | ∅ | 3/8 BSP |
| | PRESS. | Min. | 1 bar 15 PSI |
| | | Max. | 6 bar 87 PSI |
| TEMP. | Max. | 60° C. 140° F. | |
| OUT | DIAMETER | ∅ | 3/8 BSP |
| SHAFT | | ∅ | HOLLOW 5/8" |
| OIL | | SAE 75W 90 | 0.14 litri 0.03 U.S.G. |
| PESO WEIGHT | | Kg / lbs | 5.8 / 12.7 |



Con valvola depressurizzatrice e eiettore fisso incorporati
 With unloader valve and fixed injector built-in
 Avec régulateur de pression et injecteur fixe incorporés
 Con válvula de regulación de presión y eyector fijo incorporados

M - NEMA 56C -5/8"

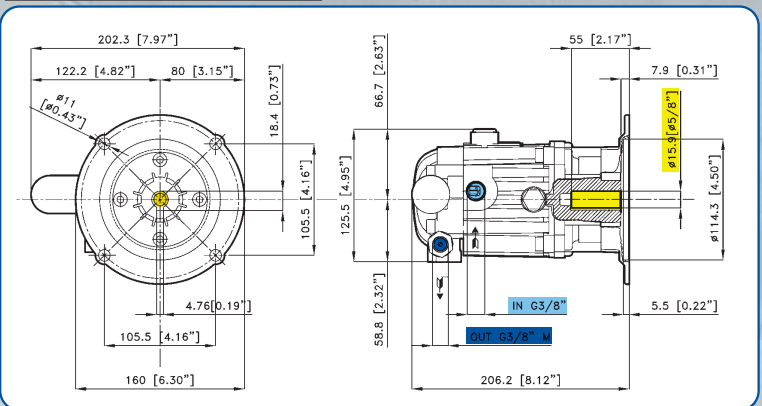

CARATTERISTICHE - FEATURES

BXH-F 3450 rpm

PERFORMANCE CHART

| CODICE CODE | MODELLO MODEL | UGELLO NOZZLE | PRESS MAX MAX PRESSURE | | PORTATA FLOW | | POTENZA POWER | | PIST. PLUNG. Dia. mm | CORSA STROKE mm |
|----------------|------------------|------------------|---------------------------|------|-----------------|-----|------------------|-----|----------------------------|-----------------------|
| | | | Bar | PSI | L/min | GPM | KW | HP | | |
| 01.6027.97.3 | BXH 1725-F | 035 | 115 | 1700 | 9.5 | 2.5 | 2.1 | 2.8 | 15 | 5.4 |
| 01.6028.97.3 | BXH 2425-F | 03 | 170 | 2400 | 9.5 | 2.5 | 3.0 | 4.0 | | |
| 01.6000.97.3 | BXH 3025-F | 02 | 210 | 3000 | 9.5 | 2.5 | 3.7 | 5.0 | | |
| 01.6029.97.3 | BXH 1730-F | 045 | 115 | 1700 | 11.4 | 3.0 | 2.6 | 3.4 | 15 | 6.8 |
| 01.6030.97.3 | BXH 2030-F | 04 | 140 | 2000 | 11.4 | 3.0 | 3.0 | 4.0 | | |
| 01.6001.97.3 | BXH 2430-F | 035 | 170 | 2400 | 11.4 | 3.0 | 3.6 | 4.9 | | |
| 01.6031.97.3 | BXH 1535-F | 055 | 105 | 1500 | 13.2 | 3.5 | 2.6 | 3.5 | 15 | 8.2 |
| 01.6032.97.3 | BXH 1735-F | 05 | 115 | 1700 | 13.2 | 3.5 | 2.9 | 3.9 | | |
| 01.6002.97.3 | BXH 2135-F | 045 | 145 | 2100 | 13.2 | 3.5 | 3.6 | 4.9 | | |

Tutti i modelli standard sono forniti con eiettore fisso ed ugello adeguato alla portata, mandata 3/8 BSP M
 All models are standard supplied with fixed injector and equivalent nozzle, outlet 3/8 BSP M
 Tous les modèles sont équipés d'injecteur fixe et buse conforme au débit, refoulement 3/8 BSP M.
 Todos los modelos estándar se proveen dotados con eyector regulable y boquilla adecuada al caudal, envío 3/8 BSP M.

Mandata M 22x1.5
 Mandata 3/8 NPT
 Eiettore fisso ugello 1.8
 Eiettore fisso ugello 2.1
 Eiettore fisso ugello 2.3
 Senza eiettore

Outlet M 22x1.5
 Outlet 3/8 NPT
 Fixed injector nozzle 1.8
 Fixed injector nozzle 2.1
 Fixed injector nozzle 2.3
 Without injector

OPTIONAL

Refoulement M 22x1.5
 Refoulement 3/8 NPT
 Injecteur fixe buse 1.8
 Injecteur fixe buse 2.1
 Injecteur fixe buse 2.3
 Sans Injecteur

Envío M 22x1.5
 Envío 3/8 NPT
 Eyector fijo boquilla 1.8
 Eyector fijo boquilla 2.1
 Eyector fijo boquilla 2.3
 Sin eyector