

# highest quality state of the art CUSTOMIZED PRECISION C53 / C75

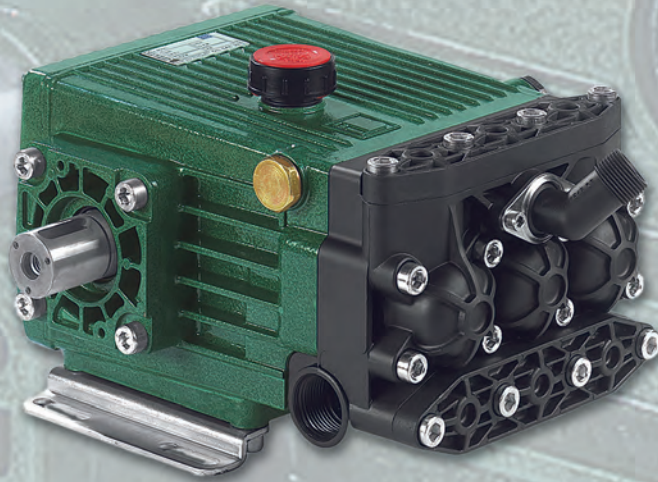

## CARATTERISTICHE - SPECIFICATIONS

		C53	C75
IN	DIAMETER	3/4 BSP	1" BSP
	PRESS.	Min. -0.2 bar - 3 PSI Max. 6 bar 87 PSI	-0.2 bar - 3 PSI 6 bar 87 PSI
	TEMP.	Max. 60° C. 140° F.	
OUT	DIAMETER	1/2 BSP   3/4 BSP M	
SHAFT		35 mm	
OIL	SAE 30 30 W	1.9 litri 0.5 U.S.G.	
PESO WEIGHT	Kg lbs	14.2 / 31.2   19 / 41.8	

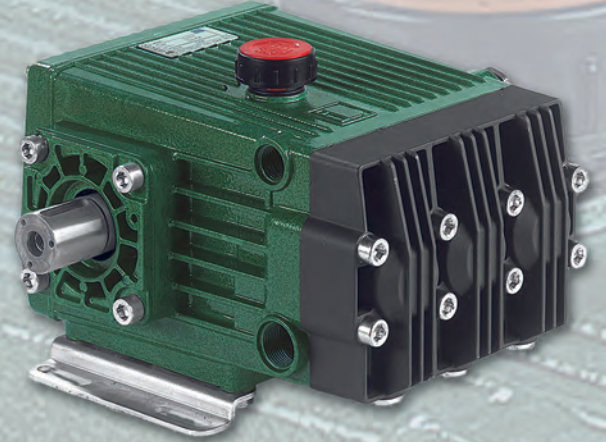

OPTIONAL

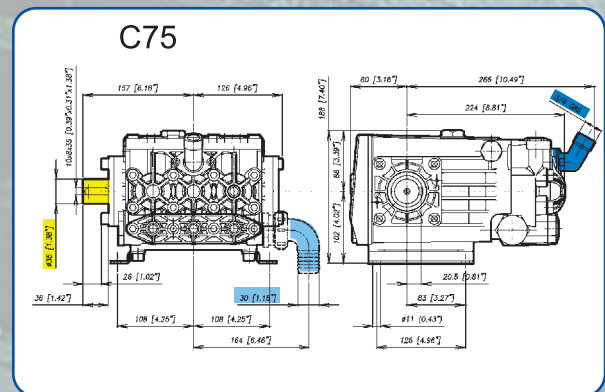
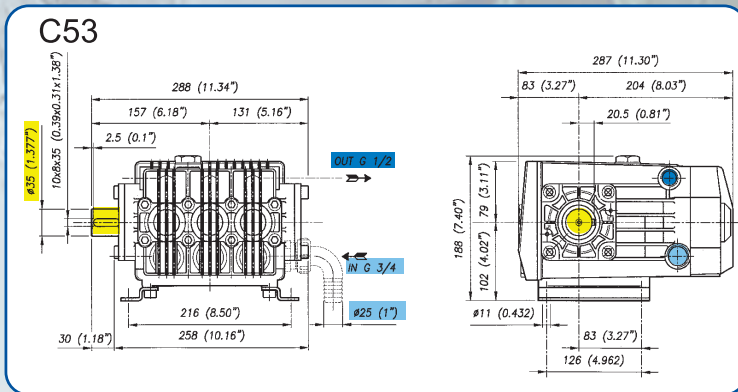
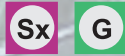

## CARATTERISTICHE - FEATURES C53 - C75 550 rpm PERFORMANCE CHART

CODICE CODE	MODELLO MODEL	PRESSIONE MAX MAX PRESSURE		PORTATA FLOW		POTENZA POWER		PIST. CORSA PLUNG. STROKE	
		Bar	PSI	l/min	GPM	KW	HP	Dia. mm	mm
53.6004.97.3	C53.2 PP	50	725	50	13.2	5.4	7.4	38	28
53.7001.97.3	C75 PP	50	725	67	17.7	6.4	8.6	38	34